

Development of an Infrared Sensor Based Automatic Load Control System for Optimum Energy Management

Olaiya O. Oluwaseun¹, Eze Blessing Ebere²

^{1,2}Department of Computer Engineering, Federal Ogun State, Nigeria

DOI: <https://doi.org/10.5281/zenodo.6962737>

Published Date: 04-August-2022

Abstract: Due to heavy loads during peak hours, blackouts have already happened in a number of countries. Significant investments are being made in the energy supply side by producing energy from alternative sources in order to reduce carbon emissions and stop any further blackouts. Therefore, increasing energy consumption efficiency on the demand side is necessary to balance this energy generation. This can be accomplished by automating the surroundings with electrical circuits and increasing people's awareness of their energy use by informing them about their usage. Since it takes into account the home energy management system, which includes both energy generation and consumption simultaneously to lower the cost of energy, this project is very beneficial for these problems.

Keywords: Power management, electronic design, infrared sensors, load control.

1. INTRODUCTION

Energy consumption rates in developing nations are higher than production rates. Therefore, it is imperative that one conserves energy within in available limits. The vast majority of electric appliances in these nations are operated by hand. Even in rooms that have been completely evacuated, electric lights and fans are frequently left on. To conserve energy, it calls for a switch to an automated system. In this study, the goal is to keep track of how many people are entering and leaving a room. The first person to enter turns on the electrical loads, and the last person to depart turns them off. Microcontroller and Infrared (IR) sensors are used to monitor all processes. Quite a bit of energy is saved in this way. The two sensor pairs are separated from one another by a specific amount. A transmitter and a receiver are kept perfectly opposite one another to make up one sensor pair. Infrared light that has been modified and released by the transmitter component is received at the receiving end and fed to an 8051 family microcontroller. With the aid of IR sensors, the microcontroller detects when someone enters the room, increases the count, shows it on seven-segment displays, and also turns on the load. The count is also decreased when someone leaves the room. The lamp is turned OFF after the last person leaves the room. A relay connected to the microcontroller manages the load action (Hasan et al., 2013; Farooq, Shakoor & Siddique, 2016; Ezurike et al., 2021).

Additionally, the project can be improved by including a timed arrangement so that, even if load switching doesn't occur as intended due to a variety of factors, the timer will still finish the task inside the designated amount of time. This project is appropriate whenever there is a critical need to regulate, cut back on, or improve energy usage. It can be used for home automation appliances, as well as in offices, conference rooms, and schools to access supply control utilizing sensor monitoring and wireless approaches. In addition, it has a very broad variety of applications across all platforms, including industrial ones. Energy management and consumption reduction improves a company's reputation while also helping to reduce climate change and save money. In order to minimize energy expenditures and mitigate environmental effects, the fundamental goal of energy management is to achieve and maintain optimal energy procurement and use across the entire business. In reality, it is commonly known that energy management is the best option for directly and immediately reducing energy use (Chowdhury, et al, 2018; Iris & Lam, 2019).

International Journal of Novel Research in Electrical and Mechanical Engineering

Vol. 9, Issue 1, pp: (45-49), Month: September 2021 - August 2022, Available at: www.noveltyjournals.com

This manuscript focuses on the creation of an automatic load control that uses an infrared (IR) sensor in conjunction with a microcontroller to conserve energy. This will imply that a computer (PC or Android) should be able to control appliances so that they can be controlled remotely. Additionally, it could improve productivity and aid in regulating energy consumption.

This section of the manuscript examines the many technologies that have been employed as energy management systems globally over the years. The project is made to keep track of how many people are entering and leaving a room. When someone enters a room, electrical loads are switched on, and when someone leaves, they are shut off. IR sensors used in combination with microcontroller to monitor all the operations. This helps in saving lot of energy. Discussed below are the technologies that were in existence before the advancement of optimum Energy.

The construction of an embedded system for home automation that uses a common remote control, temperature, humidity, and touch screen as a user input device was the main topic of the study by Hasan et al. (2013). This home automation system eliminated the difficulty of operating household appliances manually. The proposed home automation system combined a number of appealing elements that were not frequently presented in other home automation systems. This provided a complete, affordable, and effective solution for controlling a room remotely. The system can also be used to control any automatic appliances that are installed in buildings, businesses, schools, hospitals, and other places. Farooq et al. (2016) outlined the design and implementation of an autonomous room light controller and a real-time bidirectional visitor counter. The suggested system takes over control of the room lights and keeps track of who enters and exits a room. The count is increased by one as each guest enters the space, and the lights are turned on. If someone leaves the room, the count is reduced. Only when no one is there do the lights in the room turn off. Although several systems have been created in this subject, the majority of them are not usable owing to old technology. To create a system that is actually usable, cutting-edge components have been utilised in this work. To gauge the system's effectiveness, it was finally implemented and tested in real-world scenarios. The primary goal of the work of Karthik et al. (2016) was to count and display the number of people entering any space, such as a conference room or seminar hall. If someone enters the room when the lights are being switched on, the number of people will be increased. When someone leaves the room, the person count is reversed, and a relay interface can be used to turn off the power in the room when there are no more people inside. Electricity will be saved as a result. The number of people in the room is displayed on an LCD screen outside the door.

The effectiveness of steam network systems, waste heat recovery technologies, and the use of bioenergy and waste were all examined in the work of Chowdhury et al. (2018) as prospective enhancements to energy efficiency. For examination and discussion, two energy-intensive UK industries—iron and steel and food and beverage—are chosen. Since there are currently numerous energy service firms that can promote the adoption of suitable technologies, potential business models for energy efficiency are also studied. This study examines the factors influencing the proliferation of energy efficient and waste heat recovery technologies and their interconnections and interdependencies to energy consumptions. It also identifies the drivers and barriers to the adoption of energy efficiency technologies. The results contribute to highlighting the great potential for improving energy efficiency in two industrial sectors and the particular sorts of technologies applicable for certain sectoral activities. Furthermore, to improve the energy efficiency and environmental performance of ports and terminals, Iris and Lam (2019) conducted a systematic literature review to examine operational strategies (such as peak shaving, operations optimization), technology usage (such as electrification of equipment, cold-ironing, energy storage systems), renewable energy, alternative fuels, and energy management systems (such as smart grid with renewable energy). Research holes and potential directions for further study are noted. Research prospects are abundant and there is a significant possibility for ports to increase their energy efficiency, according to analysis.

Ezurike et al. (2021) developed a controller-based system that would count the number of visitors and switch on the light in the room whenever a visitor entered. It determined how many people enter a room at a given moment. PIR and LDR are used to implement this function. A seven-segment display unit is set up outside the room to display a list of everyone who entered. Every time someone enters the room, this visitor counter switches on the lights and signals that a new visitor has arrived. And when someone leaves the room using an LDR sensor, the visits counter will go down in the opposite direction. The relay interface, which is clever, switches off the light whenever no one is there.

2. METHODOLOGY

The hardware implementation involves the details of set of design specifications. It also entails the stepwise implementation and combinations of all components used on the board of the circuit in order to achieve the set objective of the project.

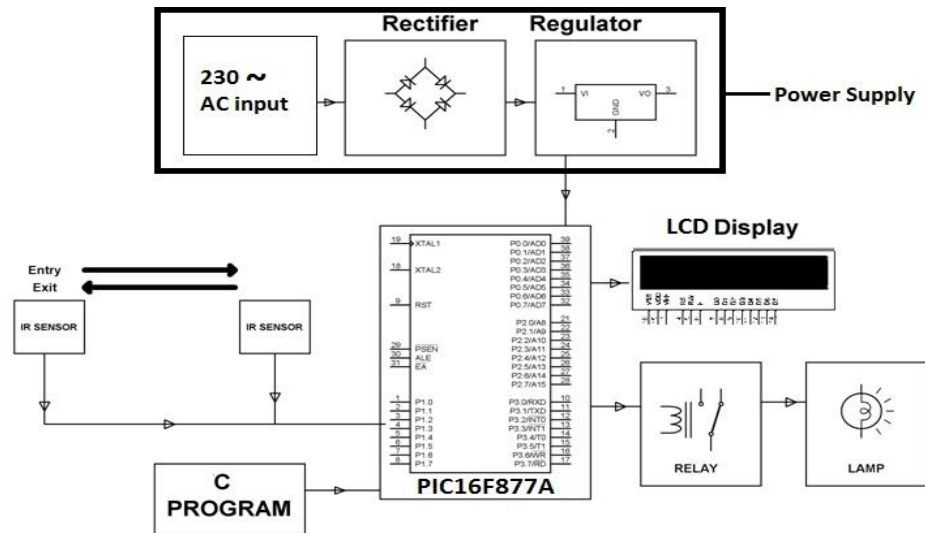

Figure 1: Block Diagram Optimum Energy Management system

There are two sets of motion sensors that are placed right next to one another and apart from one another by a specific amount. When a movement is detected, the motion sensors' logic state changes from logic 0 (low) to 1 (high), and this information is transmitted to the microcontroller (PIC16F877A). The microprocessor detects a person entering the room (with the aid of a motion sensor), increases the count, shows it on the LCD (Liquid crystal Display), and also turns on the load (electrical load). The lamp is also turned off when someone leaves the room. A relay connected to the microcontroller manages the load action.

CIRCUIT DIAGRAM

Figure 2 below describes the circuit diagram.

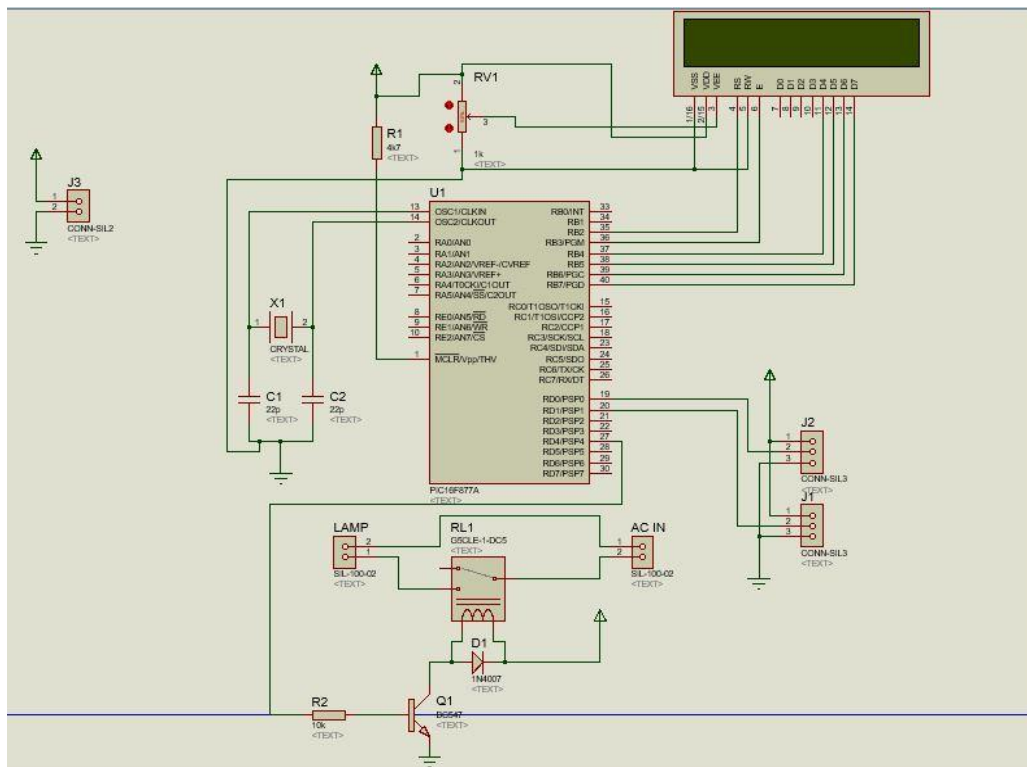

Figure 2: Circuit Diagram

SOFTWARE COMPONENTS

In this section, a detailed description of the software components used is given.

COMPILER IN MICRO-C: A potent, feature-rich development tool for PIC microcontrollers is the micro-C PRO for PIC. It is intended to offer the programmer the simplest approach to creating programs for embedded systems without sacrificing control or performance.

BUILT-IN C LANGUAGE: It can see that there are many different kinds of embedded systems all around us. Every electronic device, including a washing machine, a digital camera, and a mobile phone, has a CPU inside. The embedded software is connected to each CPU. If an embedded system's hardware serves as its body, its embedded processor serves as its brain, and its embedded software serves as its soul. The operation of embedded systems is mostly controlled by the embedded software.

PROTEUS 8 PROFESSIONAL

Software called Proteus 8 Professional can be used to simulate schematics and write PCB layout code. Lab Center Electronic Ltd. is the one who created it.

FLOW CHART

The flow chart is shown in the figure below

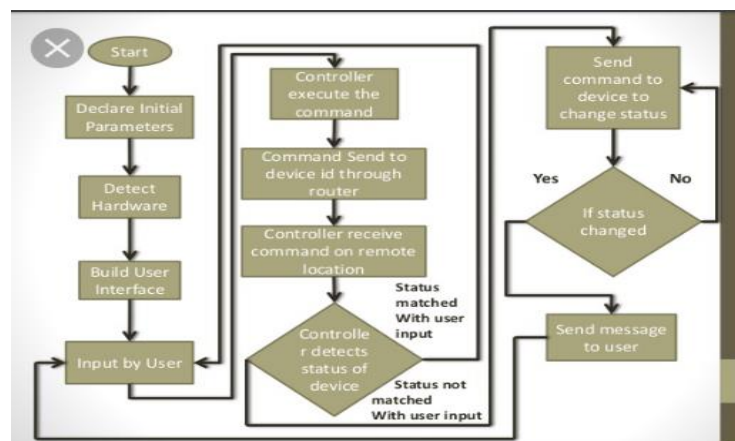

Figure 3: Flow chart

3. RESULTS, TESTING AND DISCUSSION

The construction of Optimum energy management system was interesting and challenging. These are the concluded testing and results of the project below.

RESULTS

The work was arranged on a vero Board, and the picture in figure 4 shows the arrangement of the components.



Figure 4: Internal view of the project



Figure 5: below shows the packaging and working of this project.

AREA OF IMPROVEMENT

By creating the necessary regulations and implementing energy-efficient technologies, it can be further enhanced. Additionally, a timer design ensures that the task will be completed after a set amount of time even if the preferred load change is not possible for whatever reason.

APPLICATIONS

- i. It is relevant whenever there is a strong need to regulate, cut back on, or optimize energy usage.
- ii. Its application can be found in home automation appliances, as well as in offices, conference rooms, and schools to access supply control through sensor monitoring and wireless methods.
- iii. It has a very broad range of uses across all platforms, including for industrial purposes.

4. CONCLUSION AND RECOMMENDATION

It may be concluded that employing this system to control and minimize energy use not only results in financial savings but also aids in reducing climate change and increasing corporate reputation. The proposed approach is largely regarded as the greatest option for reducing energy use directly and immediately.

This approach can be used to show how the best energy management strategy works when it is effectively put into practice and produces positive outcomes. This is a product with a good chance of being commercially successful, and today practically every family and industry uses it. As a result, each energy system can undergo a number of operations, as is the case with an ideal energy management system. The invention has a lot of potential in a futuristic setting where people are restricted in their movement and carry out their daily tasks automatically. Every household should therefore make every effort to obtain or afford this system.

REFERENCES

- [1] Chowdhury, J. I., Hu, Y., Haltas, I., Balta-Ozkan, N., & Varga, L. (2018). Reducing industrial energy demand in the UK: A review of energy efficiency technologies and energy saving potential in selected sectors. *Renewable and Sustainable Energy Reviews*, 94, 1153-1178.
- [2] Ezurike, B. O., Ajah, S. A., Nwokenkwo, U., Nwawelu, U. N., & Eze, P. (2021, August). Analysis and Modification of a Smart Light and Movement Regulator. In *Proceedings of the Second National Virtual Conference on Recent Advances in Technology & Engineering (CRATE-2021)* (Vol. 13, p. 14).
- [3] Farooq, M. U., Shakoar, A., & Siddique, A. B. (2016). ARM based Bidirectional Visitor Counter and Automatic Room Light Controller using PIR sensors. *Advances in Science, Technology and Engineering Systems Journal*, 1(5), 10-15.
- [4] Hasan, N., Khan, A. A. M., Uddin, N., & Mitul, A. F. (2013, December). Design and implementation of touchscreen and remote control based home automation system. In *2013 2nd international conference on advances in electrical engineering (ICAEE)* (pp. 347-352). IEEE.
- [5] Iris, Ç., & Lam, J. S. L. (2019). A review of energy efficiency in ports: Operational strategies, technologies and energy management systems. *Renewable and Sustainable Energy Reviews*, 112, 170-182.
- [6] Karthik, M., Shailesh, T., & Sruthi, N. (2016). *Smart Power Control System with Bidirectional Visitor Counter* (Doctoral dissertation).